

Bottle Rinser



Benefits and Features Include:

- 6 Rinse Nozzles
- Upgradeable to 12 Nozzles
- Sanitary Stainless Steel Control Parts
- Micro Processor Controller
- Recirculation System Optional
- Electric and Air Operation
- Stainless Steel Fill Nozzles
- Stainless Steel Construction
- Automatic Bottle Indexing

The automatic bottle rinser is an ideal companion to automatic bottle filling lines. The bottle rinser can utilize compressed gas to blow particulates off of the container or be used with a sanitizing solution or water to rinse bottles prior to filling. The recovery sink allows the recirculating water jet pump to recycle sanitizing solution to lower operational costs. The bottle rinser can achieve speeds of up to 60 bottles per minute with a range of ounces to one gallon without customization.

Accutek's automatic bottle rinser comes complete with an automatic bottle indexing system, soft clasp bottle gripper assembly, six individual rinsing jets, recovery sink, recirculating power

pump all based on a heavy duty, stainless steel frame.

Accutek's Automatic Bottle Rinser is a PLC operated machine controlled by an easy to use operator's alpha-numeric display. The bottle rinser can be used with any existing conveyor and set up can be completed in minutes. The versatile components and easy change over parts allow bottle change over to be completed in minutes. The "No Bottle - No Rinse" feature ensures that no chemicals or water is wasted if the bottle rinser work area is not full.

All of our equipment is manufactured on-site in Vista, California. Come and visit our showroom.

MACHINE DIMENSIONS AND SPECIFICATIONS

RINSER	Machine Length	Machine Width	Machine Height
Max. Inches	40"	30.5"	60"

Net Weight (approx.)	Shipping Weight (approx.)
250lbs.	35 lbs

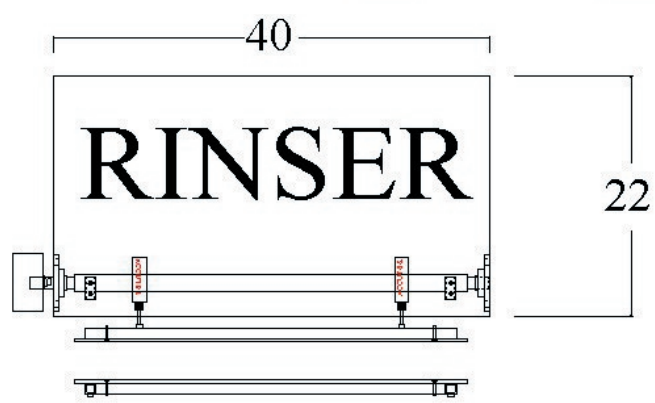
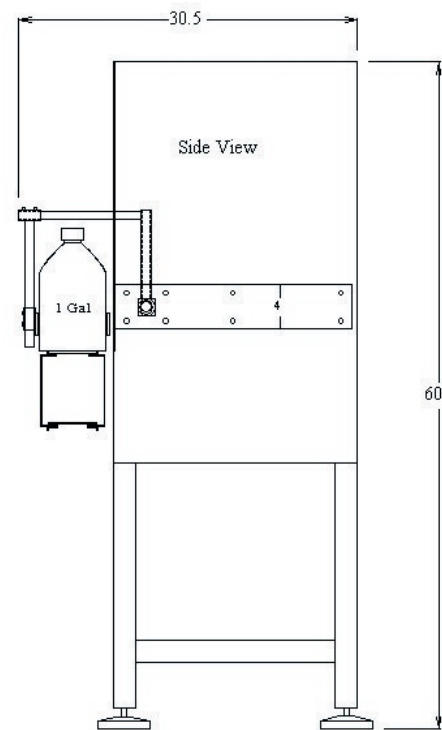
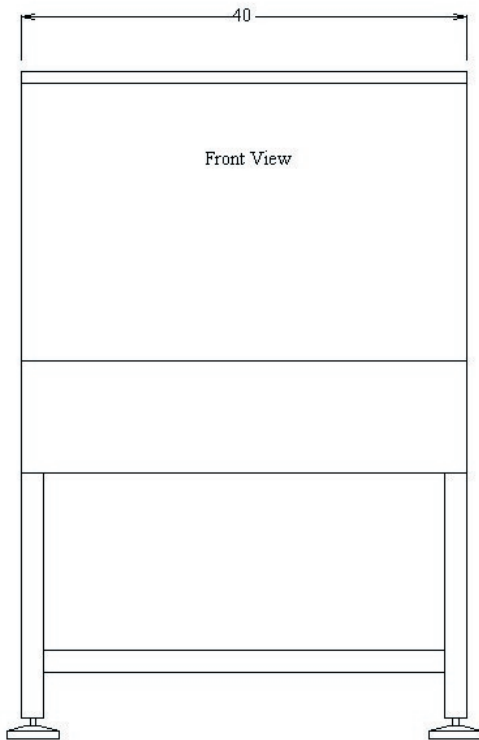

CONTAINER SIZE

Maximum: 13" Tall
Maximum: 7" diameter

ELECTRIC STANDARD

110VAC -5 AMPS

ELECTRIC OPTIONAL

220VAC

COMPRESSED AIR REQ.

70 PSI - 1CFM

EXPANDABLE FRAME

_____ For large container option

RINSING CAPABILITIES

PRODUCTS	
foamy	yes
corrosive	yes
heated	yes *
particulated	yes
flammable	yes*

*Products may require special machine adjustments.

RINSE SPEED
Up to 80 BPM (bottles per minute on 6 head)