

Labelette Labelers®

APS-228



Labelette's APS-228 is economical, self contained and easy to operate. This automatic labeling system comes equipped with a 10 ft. variable speed conveyor. Additional features include, a stepper motor drive for label, power assisted web take up, full wrap around or tamp station, auto speed adjust (all motors synchronized), and Photo Eye (non contact) sensors for label gaps and containers, auto teach for new labels. The easy to use design makes it simple to change bottle and label sizes. The APS-228 can dispense up to a 8" tall labels. You can use one or two labeling heads

Benefits and Features Include:

- In Line Automatic Applications
- Touch Screen Control System
- Built for 3 shift operations
- Welded Thick Wall Stainless Tubing Frame
- Delrin Slat Conveyor 6"wide X 7' long
- Eleven 8 in. Easy Adjusting Hand Wheels
- Infeed Separator Wheel
- Two Labeling Heads (Front & Back labeling)
- 3 Roller System (Registration & Long Labels)

Options Include:

- Hot Stamp Coder
- Bottle Separator Assembly
- Wheel Orientation For Ovals
- Top Hold Down Belt

for single or front and back containers.

The speed, versatility, and reliability of the APS-228 cases, exceeds the other industry leaders in labeling equipment technology-usually at a fraction of the price. Our Labelers are ideal for all plastic, metal, fiber, and glass containers. The APS-228 handles cylindrical as well as square and oblong containers.

All of our equipment is manufactured on-site in Vista, California. Come and visit our showroom.

1399 Specialty Drive • Vista, Ca. 92083 • Sales (800) 989-1828
Service (760) 734-4177 • Fax (760) 734-4188
www.accutekpackaging.com

APS-228

MACHINE DIMENSIONS AND SPECIFICATIONS

APS-228	Machine Length	Machine Width	Machine Height	Net Weight (approx.)	Shipping Weight (approx.)
Max. Inches	10'	54"	60"	625lbs.	700lbs.

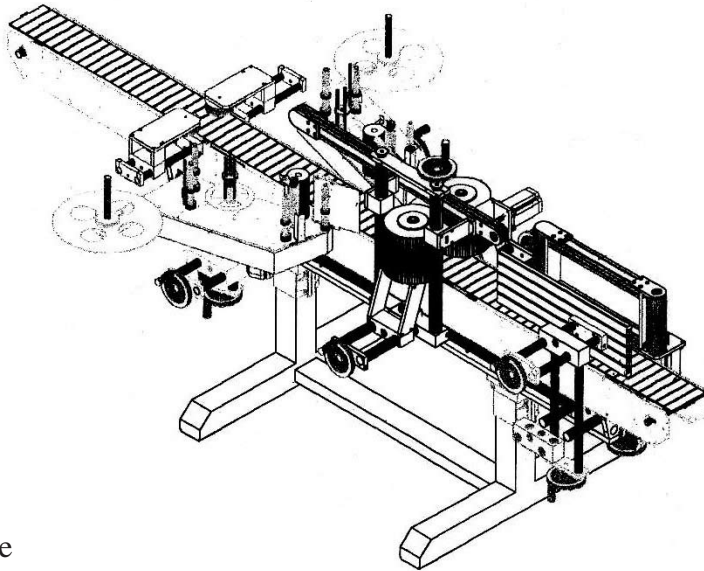
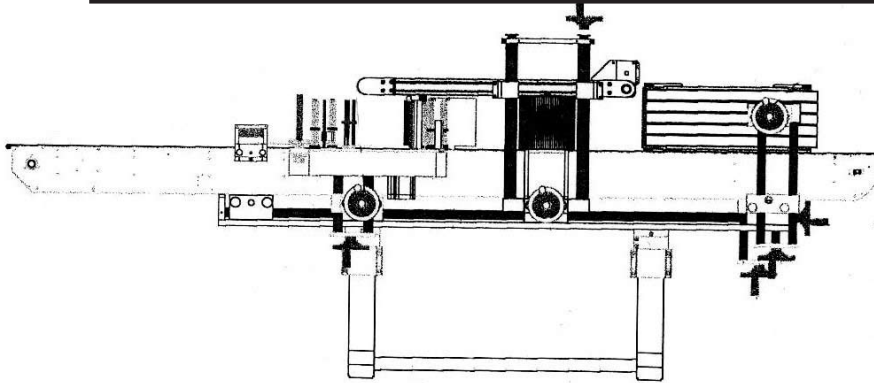

CONTAINER SIZE

Minimum: 1oz.
Maximum: 1gal.

ELECTRIC STANDARD

110VAC - 10 AMPS.
220VAC Optional

LABEL SPECIFICATIONS

Label Length .75" to 18+"
Label Height .75" to 8"
40 Meters Per Minute

PRODUCTION SPECS

Up to 200 CPM (Containers Per Min..)
Useable Conveyor Length 115"

CONVEYOR HEIGHT

35 - 37" Adjustable

Easy to use

Touch Screen Control Panel:

- Turns Conveyor On/Off
- 8 Speed Selections
- Fully Synchronized Motor Package
- Auto Teach for New Labels
- On-Screen Trouble Shooting
- Missing Label Detector
- Label Count Down (for precise run of set number of labels) to Auto-Shut Off
- Simple Straight Forward Operator Controls.

Labelette
Labelers®

1399 Specialty Drive • Vista, Ca. 92083 • Sales (800) 989-1828

Service (760) 734-4177 • Fax (760) 734-4188

www.accutekpackaging.com