

*Benefits and Features Include:*

## Auto-Pinch 25/50



The Auto-Pinch 25/50 is an automatic timed flow volumetric filling machine capable of filling water thin liquids to light oils and creams at speeds of up to 100 containers per minute. The Auto Pinch 25/50 comes standard with a heavy duty, adjustable, stainless steel base, 10' variable speed conveyor, easy to clean and autoclavable contact parts, stainless steel drip free nozzles, easy to automate bottle indexing system, and a pump.

The Automatic Bottle Indexing Unit includes a digital alpha-numeric display with the following features: no bottle - no fill, step fill or all fill modes, and a total bottle counter that can be adjusted on the fly. The ABI system is easy to set up, operate and adjust with little training.

The minimal contact parts make the Auto Pinch 25/50 ideal for sanitary filling of food, pharmaceutical, cosmetic, and specialty products. It's speed and ease of use make the Auto Pinch 25/50 the perfect machine for medium speed filling opera-

- Heavy Duty Base
- Individual Fill Head Flow Control
- User Friendly Control Box
- Food Grade Sanitary Fittings
- 10 Foot Variable Speed Conveyor
- Stainless Steel Construction
- 6 No Drip Fill Heads
- Adjustable Table Height
- 1 Pump with all Hoses and Fittings
- Automatic Bottle Indexing Unit

tions.

All of our equipment is manufactured on site in Vista, California. Come visit our fully operational show room for application demonstration.

# MACHINE DIMENSIONS AND SPECIFICATIONS

Auto-Pinch 25/50	Machine Length	Machine Width	Machine Height
Max. Inches	120 "	28 "	66 "

Net Weight (approx.)	Shipping Weight (approx.)
400 lbs.	700 lbs

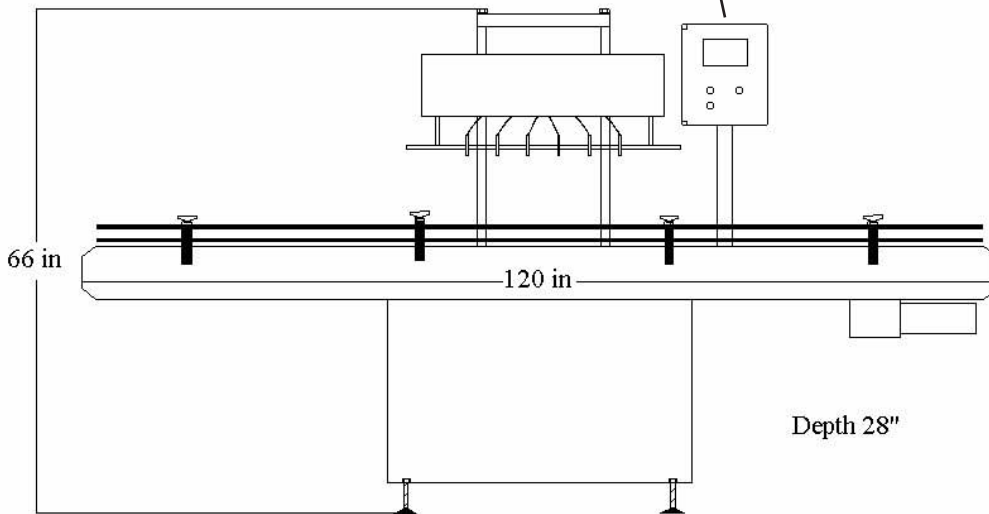

## CONTAINER SIZE

Minimum:  
 .5 oz (Auto Pinch 25)  
 8 oz. (Auto Pinch 50)

Maximum:  
 64 oz. (Auto Pinch 25)  
 128 oz. (Auto Pinch 50)

## ELECTRIC STANDARD

110 VAC/15-20 AMPS.

## ELECTRIC OPTIONAL

220 VAC

## COMPRESSED AIR REQ.

90 PSI -2 CFM.

\*Grey bar denotes maximum viscosity.

NOTE: Some upgrades may be necessary-Call for details.

Typical Liquid	Centipoise (cp)	Centistokes (cSt)	Saybolt Second Universal (SSU)
Water	1	1	31
Milk	3	4	40
No. 4 fuel oil	12.6	15.7	80
Cream	20	20.6	100
Vegetable oil	40	43.2	200
SAE 10 oil	88	110	500
Tomato Juice	180	220	1,000
SAE 30 oil	352	440	2,000
Glycerine	800	1,100	5,000
Honey	1,500	2,200	10,000
Glue	3,000	4,500	20,000
Mayonnaise	5,000	6,250	28,000
Molasses B	8,640	10,800	50,000
Sour Cream	15,000	19,000	86,000

## FILLING CAPABILITIES

PRODUCTS	
foamy	yes
corrosive	yes
heated	yes *
particulated	yes
flammable	yes*

\*Products may require special machine adjustments.

## FILL SPEED

Up to 150 BPM  
 (bottles per minute)